

# ICH E2B(R3)実装ガイド 説明会

2011年7月11日 14:35～15:05

## Health Level 7 (HL7) の概要

厚生労働科学研究「国際化を踏まえた医薬品・医療機器の  
安全性情報の伝達に関する研究」(岡田班)分担研究者

東京大学大学院 医学系研究科 臨床疫学システム講座  
E2B(R3)エキスパート 小出 大介

# なぜHL7なのか？

2006年ICHからSDOに電子的ICSRの仕様作成依頼を決定

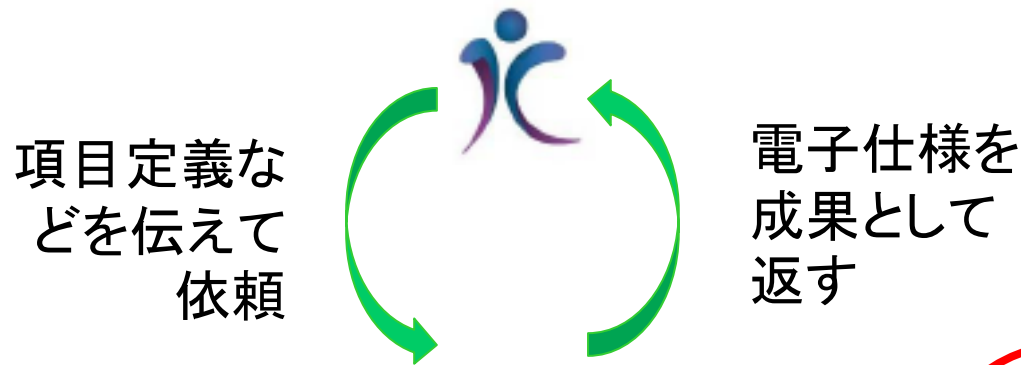

JIC: Joint Initiative Council

SDO: Standard Development Organization

# FDAがHL7を使う理由



The standards all federal agencies will adopt are:

- Health Level 7 (HL7) messaging standards to ensure that each federal agency can share information that will improve coordinated care for patients such as entries of orders, scheduling appointments and tests and better coordination of the admittance, discharge and transfer of patients.
- National Council on Prescription Drug Programs (NCDPCP) standards for ordering drugs from retail pharmacies to standardize information between health care providers and the pharmacies. These standards already have been adopted under the health insurance Portability and Accountability Act (HIPAA) of 1996, and

# 日本国内でのHL7の活用例

- 医療機関の情報システム
- 新たな治験活性化5カ年計画
  - 治験実施の効率化、企業負担の軽減
  - 「例えば、CDISC に準拠した標準仕様によるEDC とHL7 に準拠した標準仕様・・・」
- 特定健診・特定保健指導の電子的書式へのHL7 V3 CDA(Clinical Document Architecture)R2の利用
- 「保健医療情報分野の標準規格として認めるべき規格について」(医政発0331第1号 2010年3月31日)
  - HS007 患者診療情報提供書及び電子診療データ提供書(患者への情報提供)
  - HS008 診療情報提供書(電子紹介状)
  - HS012 JAHIS臨床検査データ交換規約

# ICH・ISO・HL7におけるICSRのスキープの違い

## HL7 ICSR R3

ISO ICSR Part1

対象は、医薬品・医療機器・  
サプリメント・化粧品・動物  
用医薬品

ISO ICSR Part2  
(regional extended requirements)

非医療職からの報告  
定期報告  
管理項目など

ICH E2B ICSR

対象は医薬品(ヒト用)のみ  
理由: 団体が違う  
影響の度合  
情報の違い

## E2BのICSR以外にHL7で開発するICH標準

1. M5のIDMP (Identification of Medicinal Products)
2. M8のeCTD (RPS: Regulated Product Submission)

# HL7とは

- ・1987年に設立されたヘルスケア分野のSDO
- ・非営利のボランティアな団体 (Not-for-profit Organization)
- ・民主的で、誰でも参加して意見を述べることができる
- ・会合は年3回(1月、5月、9月(総会))
- ・本部は米国、会員は55カ国以上から2300人以上(国際支部は35カ国)
  - ・日本HL7協会は1998年保健医療福祉情報システム工業会(JAHIS)内に設置
- ・特定の部門やシステムに特化せず、施設間・システム間での臨床情報や管理情報を扱う、ヘルスケア領域でのデータ交換標準の作成

日本サイト：<http://www.hl7.jp/>

国際サイト：<http://www.hl7.org>

# OSI (Open System Interconnection)参照モデル の7層とTCP/IPの4階層モデル



7	アプリケーション層	アプリケーション層
6	プレゼンテーション層	HTTP, SMTP, TELNET, FTP, SNMP, MIME, HTML
5	セッション層	
4	トランスポート層	トランスポート層 TCP, UDP
3	ネットワーク層	インターネット層 IP, ICMP
2	データリンク層	ネットワークインターフェース層 イーサネット, FDDI (ハードウェア) (光ファイバー, 同軸ケーブル)
1	物理層	



# HL7 のメンバーシップ

## HL7本部

### ◆ 個人会員

年会費\$675

### ◆ 学生会員

年会費\$140

### ◆ 団体会員

年会費\$1,200(1票:年商\$1M以下)  
~\$24,500(12票:年商\$50M以上)

### <団体会員の例>

EMA、NHSなど

FDA、CDCなど

GSK、Lilly、Pfizerなど

Microsoft、Intelなど

## 日本HL7協会

### ◆ 個人会員

入会金2,000円、年会費8,000円

### ◆ 学生会員

入会金2,000円、年会費4,000円

### ◆ ユーザー会員

入会金5,000円、年会費30,000円

### ◆ 本部会員兼

入会金2,000円、年会費800円

### ◆ 事業法人会員

入会金20,000円、年会費100,000円

### ◆ 賛助団体会員

入会金不要、年会費100,000円

# HL7会議の開催

Sep 2011 Plenary (Sep 11-16) San Diego, CA

2011年7月15日 日本HL7総会及びセミナー(ホスピタルショウ:東京)

May 2011 WGM - Orlando, FL

2011年3月 HL7セミナー(東京)

Jan 2011 WGM -- Sydney, Australia

2010年11月 HL7セミナー(医療情報学会:浜松)

Oct 2010 (Plenary) Cambridge, MA

2010年7月 日本HL7総会及びセミナー(ホスピタルショウ:東京)

May 2010 WGM Rio de Janeiro, Brazil

2010年3月HL7セミナー(大阪)

Jan 2010 WGM -- Phoenix, AZ

2009年11月HL7セミナー(医療情報学会:広島)

Sep 2009 (Plenary) - Atlanta, GA

2009年7月HL7総会及びセミナー(東京)

May 2009 WGM - Kyoto, Japan

国際会議参加費:事前(会員:\$770 非会員\$1,045) 通常(会員:\$1,045 非会員\$1,350)

# HL7 ワーキンググループ(57WG)

Affiliate Due Diligence  
Anatomic Pathology  
Architectural Review  
Arden Syntax  
Attachments  
Child Health  
Clinical Context Object Workgroup  
Clinical Decision Support  
Clinical Genomics  
Clinical Interoperability Council  
Clinical Statement  
Community Based Collaborative Care  
Domain Experts Steering Division  
Education  
Electronic Health Records  
Electronic Services  
Emergency Care  
Financial Management  
Foundation and Technology Steering  
Division  
Generation of Anesthesia Standards

Governance and Operations  
Government Projects  
Health Care Devices  
Imaging Integration  
Implementable Technology  
Specifications  
Implementation / Conformance  
Infrastructure and Messaging  
International Council  
International Mentoring Committee  
Marketing  
Modeling and Methodology  
Orders and Observations  
Organizational Relations  
Outreach Committee for Clinical  
Research  
Patient Administration  
Patient Care  
Patient Safety  
Pharmacy  
Policy Committee

Process Improvement  
Project Services  
Public Health and Emergency  
Response  
Publishing  
Recognition and Awards  
Regulated Clinical Research  
Information Management  
RIMBAA  
Roadmap Committee  
Security  
Services Oriented Architecture  
Structure and Semantic Design  
Steering Division  
Structured Documents  
Technical and Support Services  
Steering Division  
Technical Steering Committee  
Templates  
Term info Project  
Tooling  
Vocabulary

# HL7 V3 メッセージの基本 Reference Information Model (RIM)

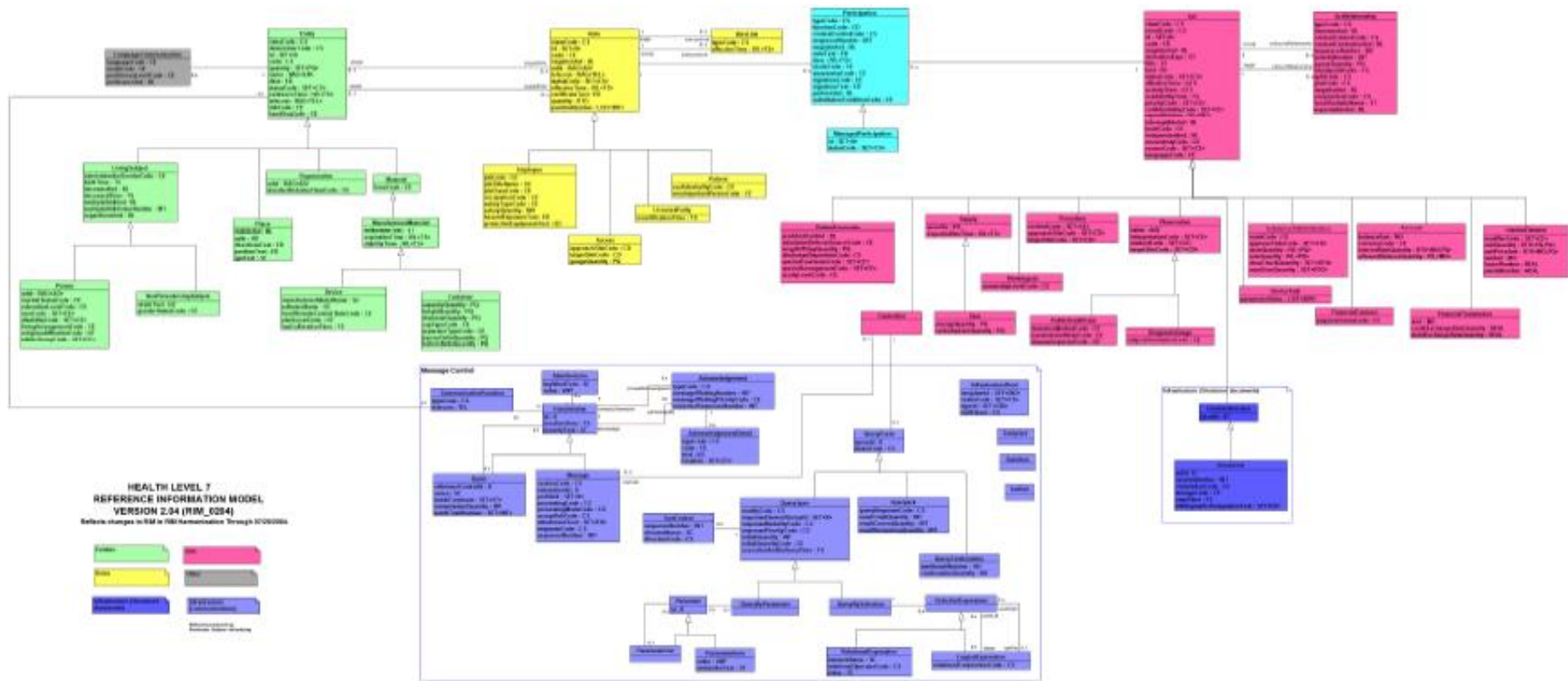

# HL7 V3 メッセージ開発フレームワーク

Use Case

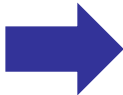

Reference Information Model (RIM)

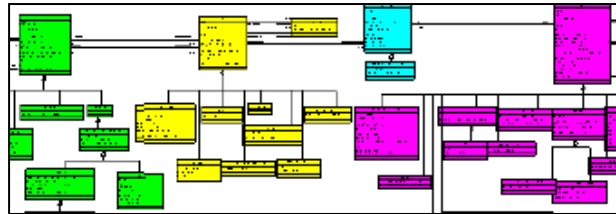

Domain Message Information Model (D-MIM)

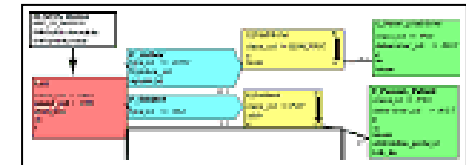
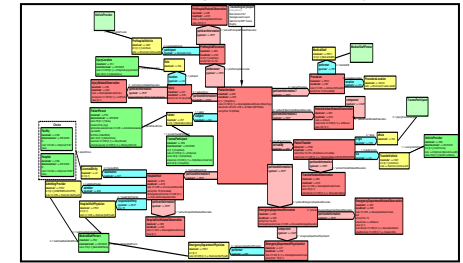

Hierarchical Message Description (HMD)

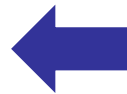

XML Schema

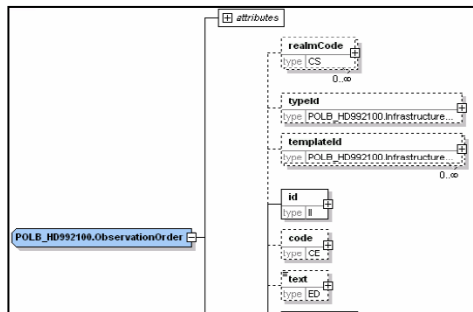

# HL7 V3 主なクラス

ACT:あらゆる出来事  
medications(薬物治療),  
procedures(処置) など

Participation : Actの  
コンテキストを定義する  
author(作成者),  
performer(実施者),  
location(場所)など

ActRelationship : Act  
間を関連づける  
precondition(前提),  
revisions(修正) など

Role:参加者  
patient(患者),  
specimen(検体)など

Entity : Roleの役割を担う  
persons(人), places(場所),  
devices(機器)など

# ISO/HL7 ICSRドキュメント

**▼ Choose a Ballot Cycle**

Click the time period below to review a ballot cycle and your participation in it.

The Cycles are ordered descending so the topmost cycle is the most current.

- ▶ [May 2011 Ballot Cycle](#)
- ▶ [January 2011 Ballot Cycle](#)
- ▶ [September 2010 Ballot Cycle](#)
- ▶ [May 2010 Ballot Cycle](#)
- ▶ [January 2010 Ballot Cycle](#)
- ▶ [September 2009 Ballot Cycle](#)
- ▶ [May 2009 Ballot cycle](#)
- ▶ [January 2009 Ballot Cycle](#)
- ▶ [September 2008 Ballot Cycle](#)
- ▶ [May 2008 Ballot Cycle](#)
- ▶ [January 2008 Ballot Cycle](#)
- ▶ [November 2007 Ballot Cycle](#)
- ▶ [September 2007 Ballot Cycle](#)
- ▶ [May 2007 Ballot Cycle](#)
- ▶ [January 2007 Ballot Cycle](#)
- ▶ [September 2006 Ballot Cycle](#)
- ▶ [May 2006 Ballot Cycle](#)
- ▶ [January 2006 Ballot Cycle](#)
- ▶ [September 2005 Ballot Cycle](#)
- ▶ [May 2005 Ballot Cycle](#)
- ▶ [January 2005 Ballot Cycle](#)
- ▶ [August 2004 Ballot Cycle](#)

**▼ Balloting Assistants**

**Balloting**

## Ballot Desktop

---

**September 2010 Ballot Cycle**  
2010SEP , Aug 23, 2010 - Sep 27, 2010

**Announcement Documents:** [Formation of Ballot Groups for HL7 JIC Pharmacovigilance Ballot for August 2010 \( pdf , 47.5 kb \)](#) [Formation of Ballot Pools for September 2010 Ballot Cycle \( pdf , 84.8 kb \)](#) [Update to Ballot Announcement for September 2010 Ballot Cycle \( pdf , 21.9 kb \)](#) [Announcement of HL7 JIC Pharmacovigilance Ballot for August 2010 \( pdf , 48.1 kb \)](#) [NonMember Participation in HL7 Ballots Instructions \( pdf , 120.8 kb \)](#) [Announcement of Ballot Openings for September 2010 Ballot Cycle \( pdf , 78.5 kb \)](#) [Seeking Interested Members to Help Us Fulfill Balance of Interest for Normative Ballot - September 2010 Ballot Cycle \( htm , 11.9 kb \)](#)

---

**Ballot Document Pools in which you ARE Participating**

There are no documents in which you are a participant in this ballot cycle. If you are not logged into the website properly you will not show up as a pool participant in any cycle.

**Ballot Document Pools in which you are NOT Participating**

**⚠ All ballots close on their specified close date at midnight, US Eastern Time Zone.**

R. Pkg	Name	Lvl.	Ballot Document	Signup Close Date	Ballot Open	Ballot Close	Cmnt
	JIC Health Informatics - Pharmacovigilance - Individual Case Safety Report, Part 1: the framework for adverse event reporting	N2	<a href="#">( 24.53 MB )</a>	Pool Closed to Signup*	Aug 14, 2010	Sep 15, 2010	
	JIC Health Informatics - Pharmacovigilance - Individual Case Safety Report, Part 2: Human pharmaceutical reporting requirements for ICSR	N2	<a href="#">( 24.24 MB )</a>	Pool Closed to Signup*	Aug 14, 2010	Sep 15, 2010	

[http://www.hl7.org/ctl.cfm?action=ballots.home&ballot\\_cycle\\_id=521&ballot\\_voter\\_id=0](http://www.hl7.org/ctl.cfm?action=ballots.home&ballot_cycle_id=521&ballot_voter_id=0)

# ISO/HL7 ICSR Part2

Part 2:  
ISO 27953-2

[Cover](#)

[Contents](#)

[Foreword](#)

[0 Introduction](#)

[1 Scope](#)

[2 Normative references](#)

[3 Terms and definitions](#)

[4 Abbreviated terms](#)

[5 Human Pharmaceuticals](#)

[Message Specification](#)

[Annex A \(normative\)](#)

[Transmission Infrastructure](#)

[Annex B \(normative\)](#)

[Control Act Infrastructure](#)

[Annex C \(informative\) HL7](#)

[Common Product Model](#)

[Annex D \(informative\) HL7](#)

[Version 3 Guide](#)

[Annex E \(informative\) HL7](#)

[Reference Information](#)

[Model](#)

[Annex F \(informative\) HL7](#)

[Data Type Specifications](#)

[Annex G \(informative\) HL7](#)

[Vocabulary Specifications](#)

[Bibliography](#)



DRAFT INTERNATIONAL STANDARD ISO 27953-2

Third edition 2010-02-25

## Health informatics – Pharmacovigilance – Individual case safety report – Part 2: Human pharmaceutical reporting requirements for ICSR

Partie 0002:

[ISO 27953-2](#)

This ISO/HL7 document is a Draft International Standard and is copyright-protected by ISO and Health Level Seven. Except as permitted under the applicable laws of the user's country, neither this ISO/HL7 draft nor any extract from it may be reproduced, stored in a retrieval system or transmitted in any form or by any means, electronic, photocopying, recording or otherwise, without prior written permission being secured.

Requests for permission to reproduce should be addressed to either ISO at the address below or ISO's member body in the country of the requester. In the United States, such requests should be sent to HL7.

ISO copyright office  
Case postale 56 • CH-1211 Geneva 20



# ISO/HL7 ICSR Part2

Part 2:  
ISO 27953-2

[Cover](#)

[Contents](#)

[Foreword](#)

[0 Introduction](#)

[1 Scope](#)

[2 Normative references](#)

[3 Terms and definitions](#)

[4 Abbreviated terms](#)

**[5 Human Pharmaceuticals  
Message Specification](#)**

[Annex A \(normative\)](#)

[Transmission Infrastructure](#)

[Annex B \(normative\) Control Act  
Infrastructure](#)

[Annex C \(informative\) HL7](#)

[Common Product Model](#)

[Annex D \(informative\) HL7](#)

[Version 3 Guide](#)

[Annex E \(informative\) HL7](#)

[Reference Information Model](#)

[Annex F \(informative\) HL7 Data](#)

[Type Specifications](#)

[Annex G \(informative\) HL7](#)

[Vocabulary Specifications](#)

[Bibliography](#)

[Go To Top](#)

▶ **Refined Message Information Models (Sorted by Title)**

▼ **Refined Message Information Models (Sorted by Display Order)**

• HumanPharmaceuticalsBaseRMIM ([PORR\\_RM049016UV](#))

• HumanPharmaceuticalsPRRIModel ([PORR\\_RM049023UV](#))

## Reference

For details on the interpretation of this section, see [the description of RMIMs](#) in the Version 3 Guide.

### ● 5.5.1 HumanPharmaceuticalsBaseRMIM (PORR\_RM049016UV)

#### Diagram

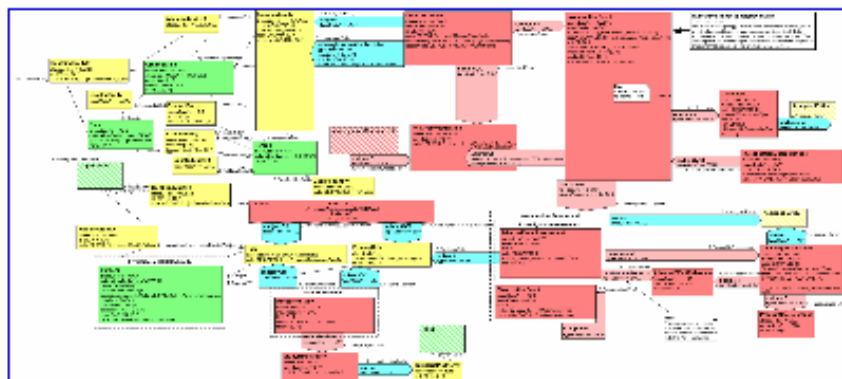

#### Description

#### Model Overview

The Human Pharmaceuticals Base Model RMIM is designed to support a

# ISO/HL7 ICSR Part2のR-MIM

## Entity Role Participation Act, ActRelationship

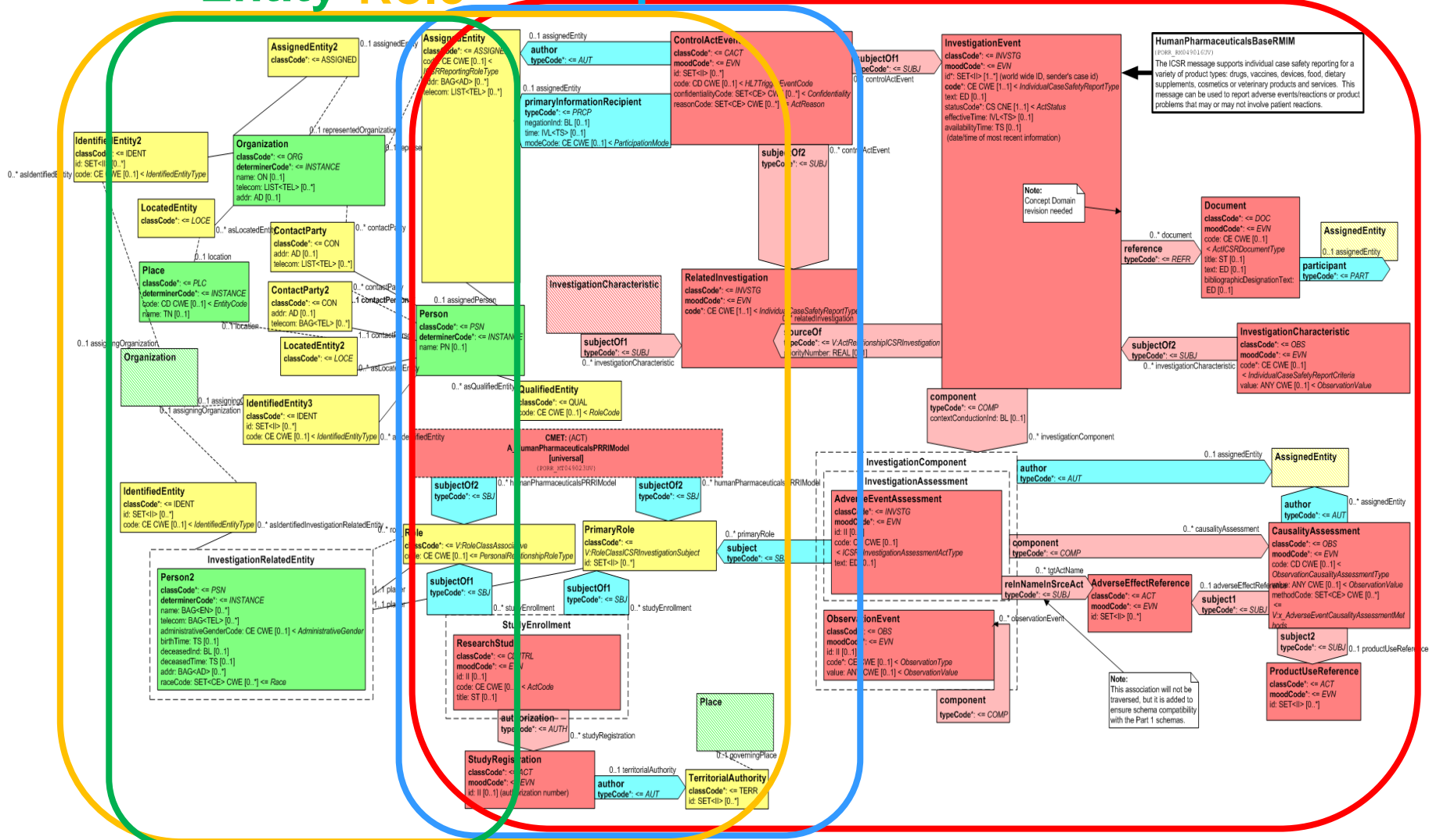

# ISO/HL7 ICSR Part2 R-MIMの説明

## (Act, Act Relationship, Participation)

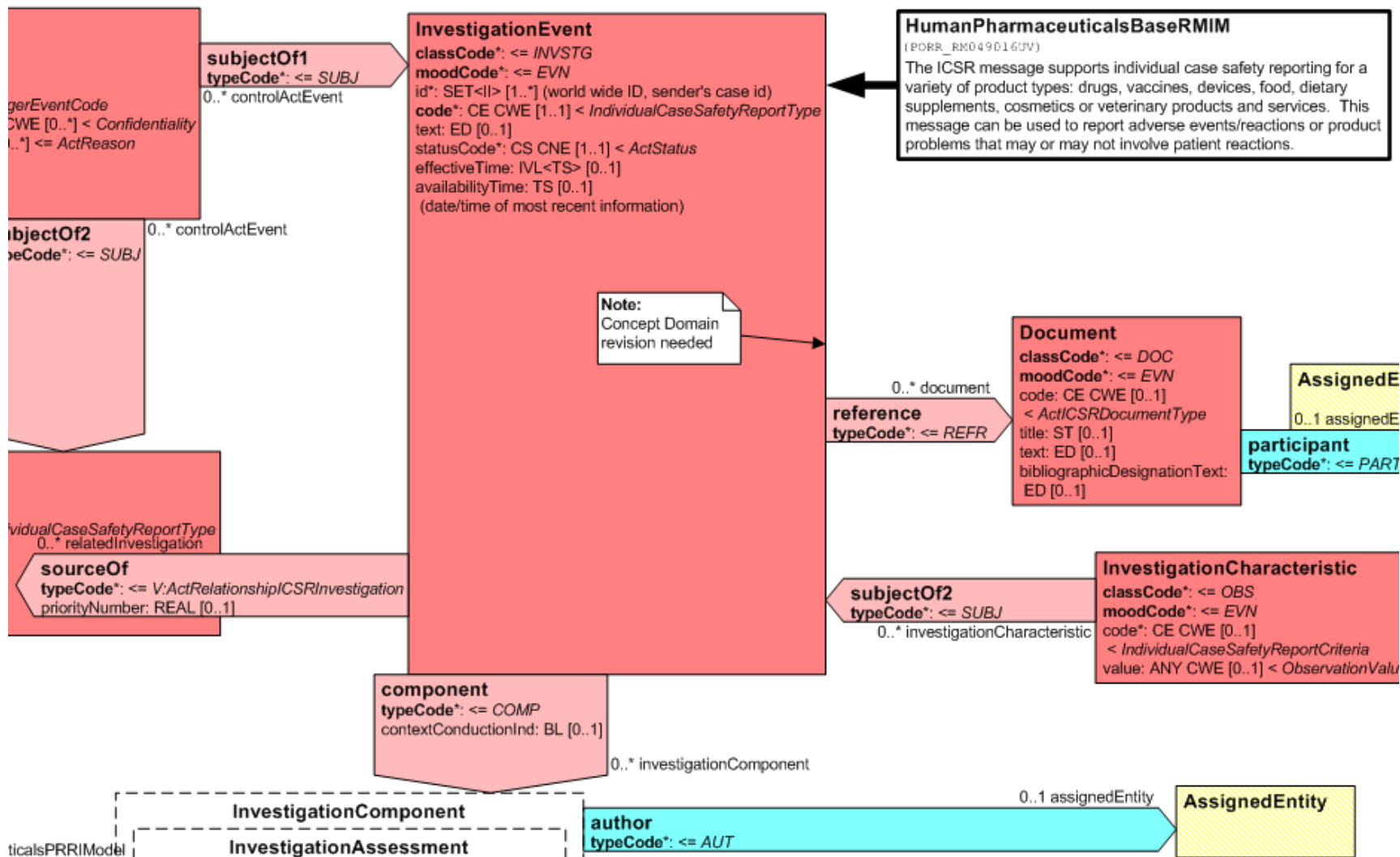

# ISO/HL7 ICSR Part2 R-MIMの説明 (Role, Entity)

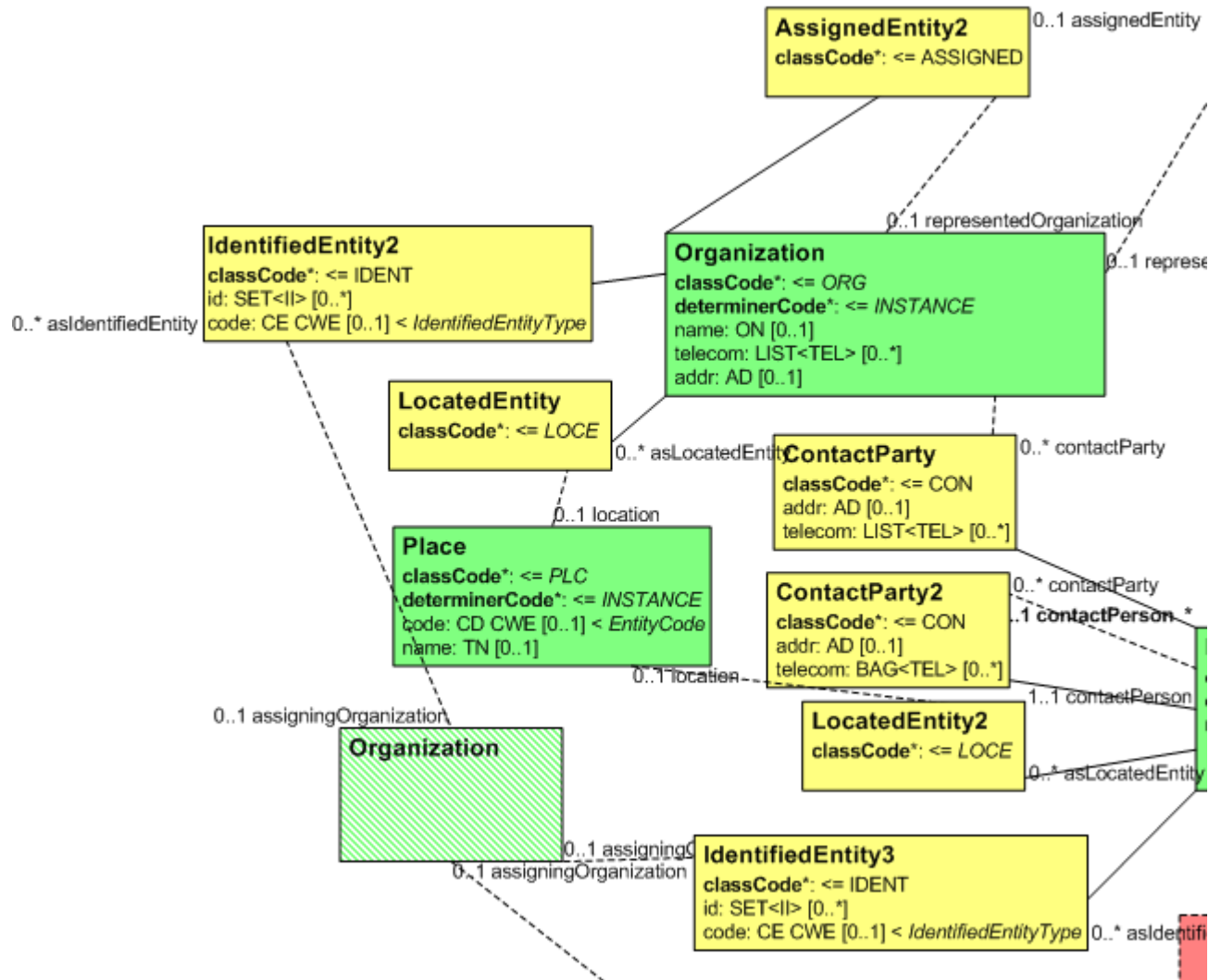

# ISO/HL7 ICSR Part2のスキーマ例

```
<?xml version="1.0" encoding="UTF-8"?>
- <xs:schema elementFormDefault="qualified" targetNamespace="urn:hl7-org:v3" xmlns:mif="urn:hl7-org:v3/mif" xmlns="urn:hl7-org:v3"
  xmlns:xs="http://www.w3.org/2001/XMLSchema" xmlns:mif2="urn:hl7-org:v3/mif2">
  - <xs:annotation>
    <xs:documentation>Source Information Rendered by: RoseTree 4.2.50 Rendered on: This document was rendered into XML using software
      provided to HL7 by Beeler Consulting LLC. PubDB to MIF Transform: $RCSfile: PubDbXmlToMIF.xml,v $ $Revision: 1.11 $ $Date:
      2007/10/19 05:55:13 $ Fix names transform: $Id: FixMifNames.xml 8355 2009-10-07 03:16:34Z lloyd_mckenzie $ HTML to MIF Markup
      transform: $Id: HtmlToMIFMarkup.xml 8384 2010-04-12 17:34:28Z woody_beeler $ Base transform: $Id: ConvertBase.xml 8360 2009-10-
      26 06:00:22Z woody_beeler $ Package Id Conversion: $Id: TransformPackageIds.xml 8398 2010-10-12 01:52:15Z lloyd_mckenzie $
      Generated using schema builder version: 3.4.4 and DynamicMifToXSD.xml version: 1.4 Dynamic MIF to Schema Transform: $Id:
      DynamicMifToXsd.xml 8355 2009-10-07 03:16:34Z lloyd_mckenzie $ Static MIF to Schema Transform: $Id: StaticMifToXsd.xml 8419 2010-
      11-15 00:10:54Z woody_beeler $ Package Id Conversion: $Id: TransformPackageIds.xml 8398 2010-10-12 01:52:15Z lloyd_mckenzie
    </xs:documentation>
  </xs:annotation>
  <xs:include schemaLocation="../coreschemas/infrastructureRoot.xsd"/>
  <xs:include schemaLocation="MCCI_MT000100UV01.xsd"/>
  <xs:include schemaLocation="MCAI_MT700201UV01.xsd"/>
  <xs:include schemaLocation="PORR_MT049016UV.xsd"/>
  - <xs:element name="PORR_IN049016UV">
    - <xs:complexType>
      - <xs:complexContent>
        - <xs:extension base="PORR_IN049016UV.MCCI_MT000100UV01.Message">
          <xs:attribute name="ITSVersion" fixed="XML_1.0" use="required" type="xs:string"/>
        </xs:extension>
      </xs:complexContent>
    </xs:complexType>
  </xs:element>
  - <xs:complexType name="PORR_IN049016UV.MCCI_MT000100UV01.Message">
    - <xs:sequence>
      <xs:group ref="InfrastructureRootElements"/>
      <xs:element name="id" type="II" maxOccurs="1" minOccurs="1"/>
      <xs:element name="creationTime" type="TS" maxOccurs="1" minOccurs="1"/>
      <xs:element name="securityText" type="ST" maxOccurs="1" minOccurs="0"/>
      <xs:element name="versionCode" type="CS" maxOccurs="1" minOccurs="0"/>
      <xs:element name="interactionId" type="II" maxOccurs="1" minOccurs="1"/>
      <xs:element name="profileId" type="II" maxOccurs="unbounded" minOccurs="0"/>
      <xs:element name="processingCode" type="CS" maxOccurs="1" minOccurs="1"/>
      <xs:element name="processingModeCode" type="CS" maxOccurs="1" minOccurs="1"/>
      <xs:element name="acceptAckCode" type="CS" maxOccurs="1" minOccurs="1"/>
      <xs:element name="sequenceNumber" type="INT" maxOccurs="1" minOccurs="0"/>
      <xs:element name="attachmentText" type="ED" maxOccurs="unbounded" minOccurs="0"/>
      <xs:element name="receiver" type="MCCI_MT000100UV01.Receiver" maxOccurs="unbounded" minOccurs="1"/>
      <xs:element name="respondTo" type="MCCI_MT000100UV01.RespondTo" maxOccurs="unbounded" minOccurs="0" nillable="true"/>
      <xs:element name="sender" type="MCCI_MT000100UV01.Sender" maxOccurs="1" minOccurs="1"/>
      <xs:element name="attentionLine" type="MCCI_MT000100UV01.AttentionLine" maxOccurs="unbounded" minOccurs="0" nillable="true"/>
      <xs:element name="controlActProcess" type="PORR_IN049016UV.MCAI_MT700201UV01.ControlActProcess" maxOccurs="1"
        minOccurs="1"/>
    </xs:sequence>
  </xs:complexType>
</xs:schema>
```



# ISO/HL7 ICSR Part2による ICHICSRインスタンス例(IGより)

## 2196 APPENDIX IV - EXAMPLES AND SAMPLE MESSAGES

### 2197 Appendix IV (A) Sample ICSR Message Instance

2198 The XML instance below is intended to assist tool developers by providing a reasonably complete  
2199 representation of the content that would be contained in an ICSR message. It is not a complete  
2200 message as the message header is missing. This instance does not contain every possible individual  
2201 data element as some data elements can not logically be combined. The structure of the instance is  
2202 technically sound and it can be used as a baseline going forward.

```
2203  
2204 <?xml version="1.0" encoding="UTF-8"?>  
2205 <MCCI_IN200100UV01 ITSVersion="XML_1.0" xsi:schemaLocation="urn:hl7-org:v3  
2206 MCCI_IN200100UV01.xsd" xmlns="urn:hl7-org:v3" xmlns:mif="urn:hl7-org:v3/mif"  
2207 xmlns:xsi="http://www.w3.org/2001/XMLSchema-instance">  
2208   <id extension="M.1.4" root="sender-identifier-value"/>  
2209   <!-- M.1.4: Batch Number -->  
2210   <creationTime value="20101214151617"/>  
2211   <!-- M.1.7: Date of Batch Transmission -->  
2212   <responseModeCode code="D"/>  
2213   <interactionId extension="MCCI_IN200100UV01" root="2.16.840.1.113883.1.6"/>  
2214   <name code="M.1.1" codeSystem="ich-type-of-message-in-batch-oid"/>  
2215   <!-- M.1.1: Type of Messages in Batch -->  
2216   <!-- Message #1 -->  
2217   <PORR_IN049016UV>  
2218     <id extension="M.2.r.4" root="ich-senders-safety-report-identifier-oid"/>  
2219     <!-- M.2.r.4: Message Identifier -->  
2220     <creationTime value="20101214151617"/>  
2221     <!-- M.2.r.7: Date of Message Creation -->
```

# HL7を用いたICH ICSRの送受信

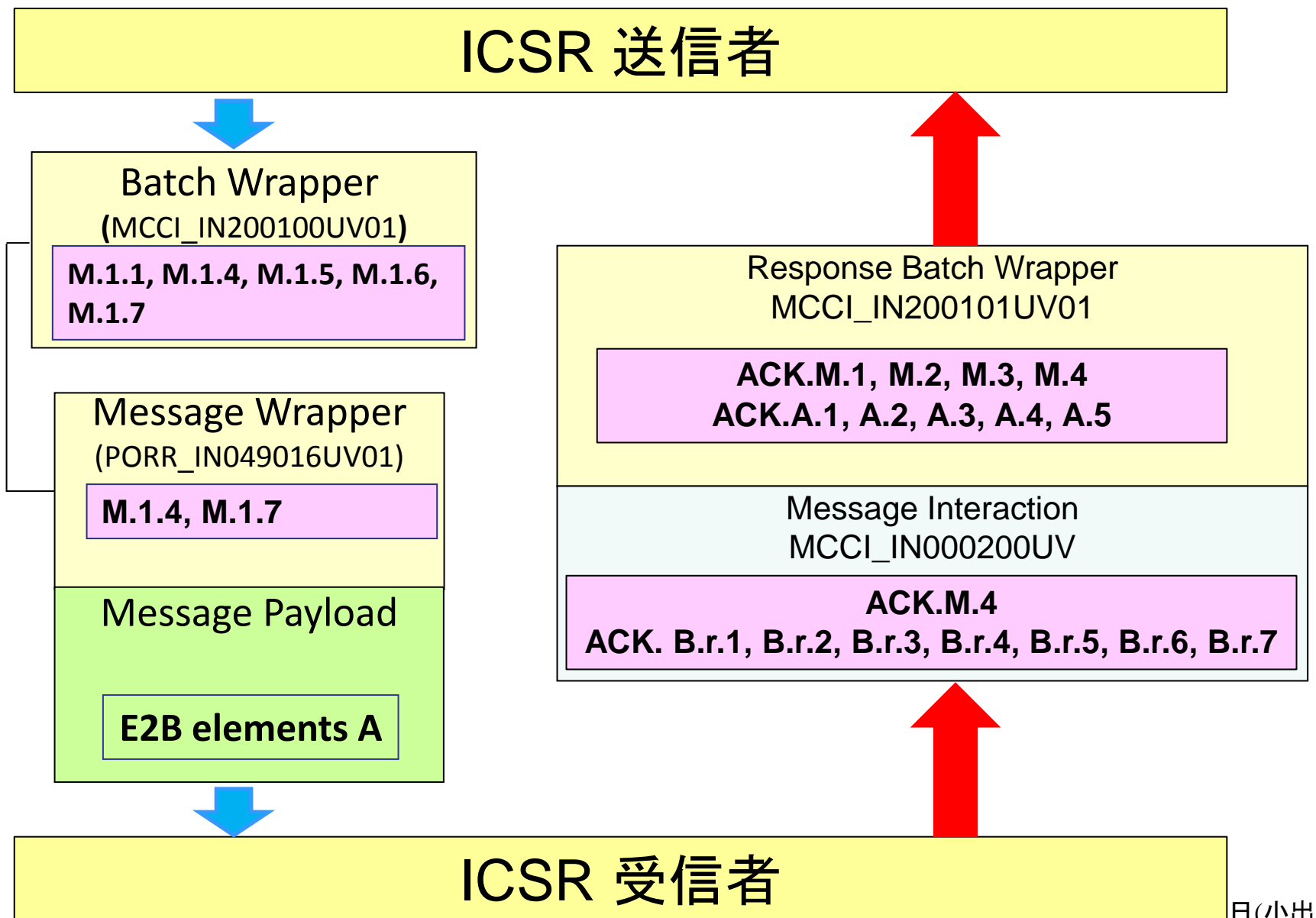

# HL7を用いたICH ICSRの画面例

The screenshot displays a software interface for an ICH ICSR form. At the top, there are buttons for 'Open', 'Save As', and 'Save'. Below these are several tabs: 'Safety Report', 'Primary source(s)', 'Information on sender', 'Patient characteristics', 'Parent characteristics', 'Reaction(s)/event(s)', 'Results', 'Drug(s)', and 'Case summary'. The 'Safety Report' tab is currently selected. The main content area is titled 'IDENTIFICATION OF THE CASE SAFETY REPORT' and contains the following fields:

- Sender's case Identifier:
- Date of Transmission:  example(YYYYMMDDHHmmSS)
- Type of Report:
- Date report was first received from source:  example(YYYYMMDD)
- Date of the most recent information for this case:  example(YYYYMMDD)

Below these fields, there is a question 'Are additional documents available?' with a dropdown menu. At the bottom left, there are two buttons: 'Add document' and 'Delete document'.



# 参考図書

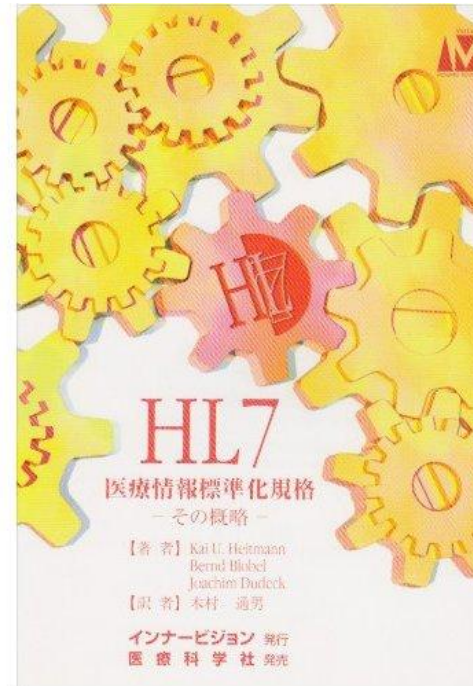
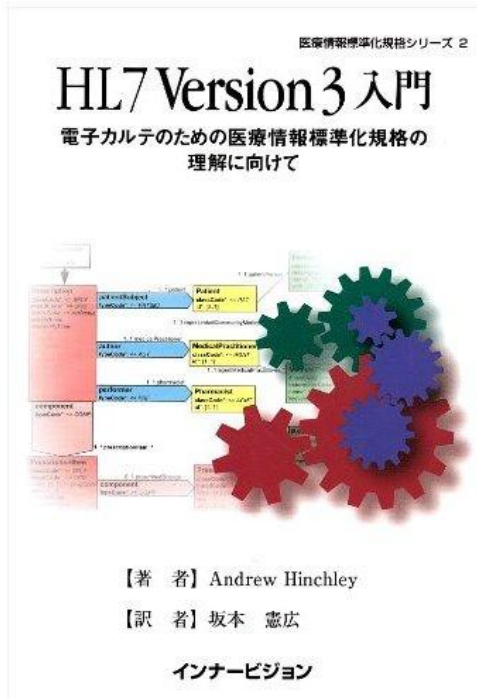

監修 木村通男(浜松医科大学教授)  
著者 Andrew Hinchley(HL7 UK)  
訳者 坂本 憲広(神戸大学医学部教授)  
体裁 ■ A5判(並製) ■ 108頁  
発行 2003年11月20日  
本体価格 2,100円(本体価格 2,000円)  
発行元 株式会社 インナービジョン  
〒113-0033 東京都文京区本郷3-15-1  
TEL 03-3818-3502 FAX 03-3818-3522  
<http://www.innervision.co.jp/>

著者 Kai U. Heitmann, Bernd Blobel, Joachim Dudeck  
訳者 木村 通男(浜松医科大学教授)  
体裁 ■ A5判(並製) ■ 52頁  
発行 2002年3月1日  
本体価格 1,260円(本体価格 1,200円)  
発行元 株式会社 インナービジョン  
〒113-0033 東京都文京区本郷3-15-1  
TEL 03-3818-3502 FAX 03-3818-3522  
<http://www.innervision.co.jp/>